

Introduction to SONET

Optical Networks

- Networks using optical fiber can be thought as client layers of optical layer
 - Backbone
 - Access
 - Metro
- Backbone optical fiber client layers
 - SONET / SDH
 - Ethernet
 - Optical Transport Network

Other Client Layers - Metro

- Gigabit Ethernet
- 10-Gigabit Ethernet
- Fibre Channel (storage network)
- Resilient Packet Ring (RPR) – packet traffic
- SONET/SDH

SONET/SDH

- SONET/SDH: first generation of optical networks deployed in backbone networks
- Supports constant bit rate (CBR) connections
- Multiplexes CBR connections into higher speed optical connections by using time division multiplexing
- Originally designed for low speed voice and CBR connections, up to 51 Mb/s
- Supports data network, packet traffic that can have link transmission rates in the tens of gigabits per second.
- It provides carrier grade service of high availability

SONET Layers

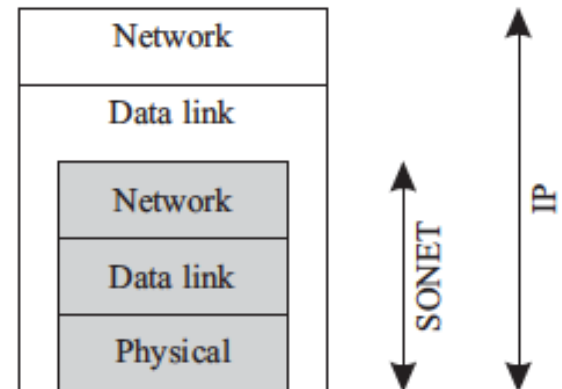
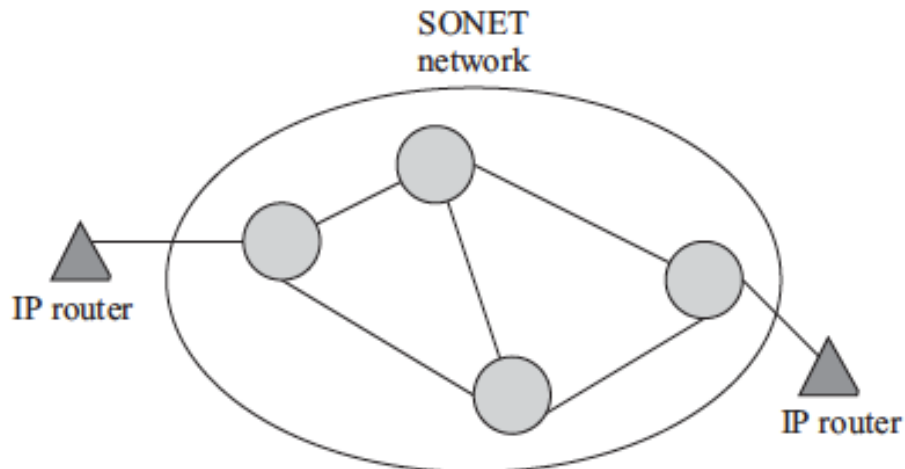
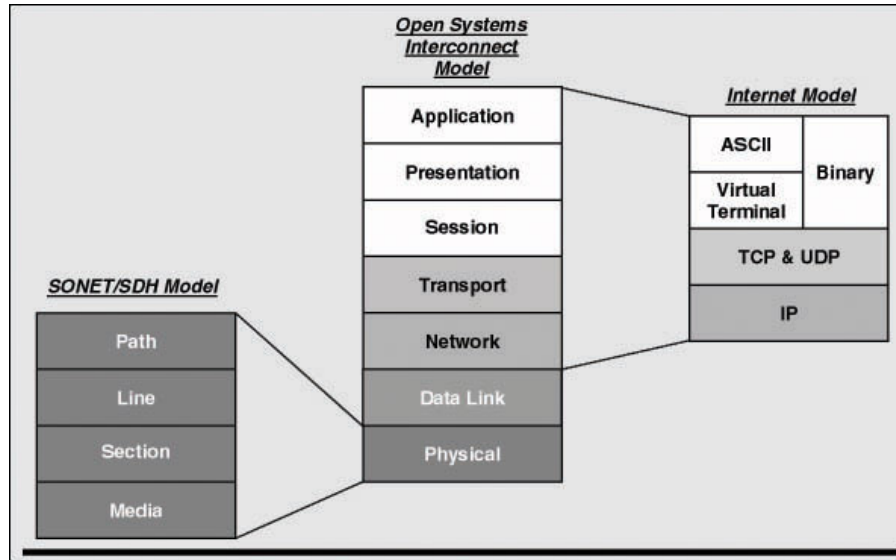

SONET/SDH

- Synchronous Optical Network
 - Transmission and multiplexing standard for high-speed signals within the carrier infrastructure in North America
- SDH (Synchronous Digital Hierarchy), has been adopted in Europe and Japan

SONET Timing

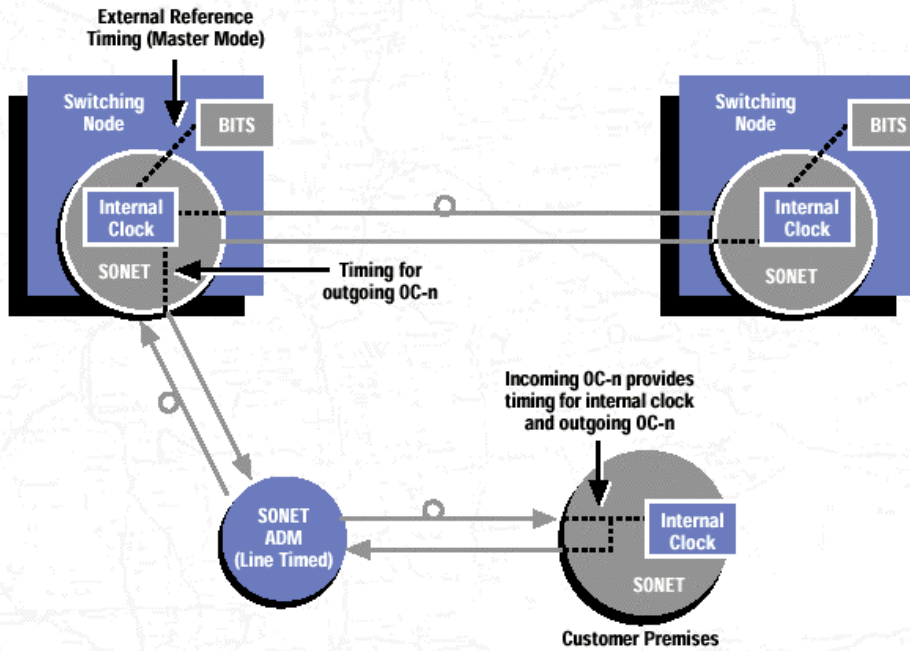

Synchronizing a SONET Network

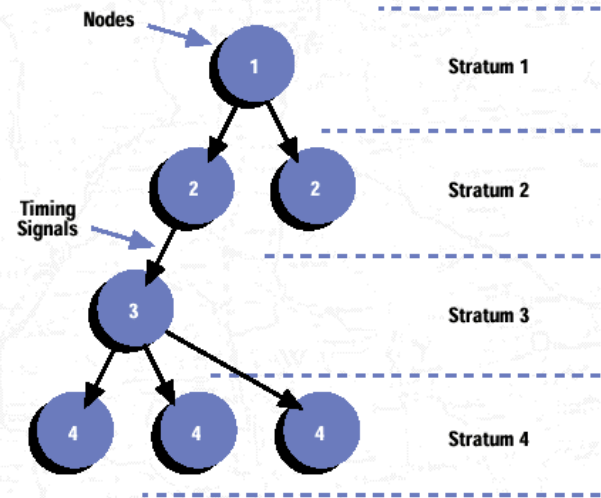

Digital Network Synchronization Hierarchy

Synchronization vs. Plesiochronous

- Plesiochronous digital hierarchy (PDH)
 - Known as asynchronous digital hierarchy in North America
 - Used for multiplexing digital voice circuits
 - 4KHz Bandwidth
 - Sampled at 8KHz
 - Bit rate of 64 kbps (basic stream)
 - Higher speeds are achieved by multiple of basic stream
- In North America the basic voice rate is called digital signal – n
 - E.g., DS0, DS1,
- In Europe this hierarchy is labeled as E0, E1, E2, E3, & so on

Level	North America	Europe	Japan
0	0.064 Mb/s	0.064 Mb/s	0.064 Mb/s
1	1.544 Mb/s	2.048 Mb/s	1.544 Mb/s
2	6.312 Mb/s	8.448 Mb/s	6.312 Mb/s
3	44.736 Mb/s	34.368 Mb/s	32.064 Mb/s
4	139.264 Mb/s	139.264 Mb/s	97.728 Mb/s

Plesiochronous - Issues

- Each system has its own clock (asynchronous) – nominal clock
 - Difference in clock can generate serious synch. Issues
 - 20 ppm difference between clocks → 1.8 kbps bit rate difference
 - Bit stuffing is typically used to compensate for difference in transmission rates
 - Transmission rates are not exactly integral multiple of the basic rate (64 kbps)
 - DS1 (1.544 Mbps) > 24 x 64 kbps !
 - In order to extract lower rate the entire signal has to be demultiplexed – expensive!
- Provides little/no management information including performance monitoring
- Offers little standards for reliability

SONET / SDH Standards - Advantages

- Higher bit rates are integral multiples of lower rates
- All clocks are perfectly synchronized (via a master clock)
- Incorporate extensive management information, e.g., performance monitoring
- Provides interoperability between different devices by different vendors
- Fast restoration time (much longer in PDH)

SONET / SDH Multiplexing

- SONET basic rate is 51.84 Mbps
 - Called the synchronous transport signal level-1 (STS-1)
 - STS is an electrical signal
 - It uses **scrambling** (to avoid long runs of 1s and zeros)
 - Higher rate signals (STS-N) are obtained by interleaving N frames
 - No need for bit stuffing
 - Simple demultiplexing process
- Optical interfaces of STS-N are labeled as OC-N

SONET Signal	SDH Signal	Bit Rate (Mb/s)
STS-1		51.84
STS-3	STM-1	155.52
STS-12	STM-4	622.08
STS-24		1244.16
STS-48	STM-16	2488.32
STS-192	STM-64	9953.28
STS-768	STM-256	39,814.32

Level	North America	Europe	Japan
0	0.064 Mb/s	0.064 Mb/s	0.064 Mb/s
1	1.544 Mb/s	2.048 Mb/s	1.544 Mb/s
2	6.312 Mb/s	8.448 Mb/s	6.312 Mb/s
3	44.736 Mb/s	34.368 Mb/s	32.064 Mb/s
4	139.264 Mb/s	139.264 Mb/s	97.728 Mb/s

SONET Hierarchy

SONET Hierarchy

Signal	Bit Rate	Capacity
STS-1, OC-1	51.840 Mb/s	28 DS1s or 1 DS3
STS-3, OC-3	155.520 Mb/s	84 DS1s or 3 DS3s
STS-12, OC-12	622.080 Mb/s	336 DS1s or 12 DS3s
STS-48, OC-48	2488.320 Mb/s	1344 DS1s or 48 DS3s
STS-192, OC-192	9953.280 Mb/s	5376 DS1s or 192 DS3s
STS-768, OC-768	39813.12 Mb/s	21504 DS1s or 768 DS3s

STS = Synchronous Transport Signal

OC = Optical Carrier

Non-Synchronous Hierarchy

Signal	Bit Rate	Channels
DS0	64 kb/s	1 DS0
DS1	1.544 Mb/s	24 DS0s
DS2	6.312 Mb/s	96 DS0s
DS3	44.736 Mb/s	28 DS1s

SONET Frame

- SONET frame
 - Overhead bytes called transport overhead
 - Payload
 - STS payload is carried in synchronous payload envelope (SPE)
 - SPE contains additional path overhead
- SONET uses pointers to indicate the location of the payload data within the frame
 - Clock phase differences can be compensated using pointer adjustments (no bit stuffing)
 - Pointer processing is complex!

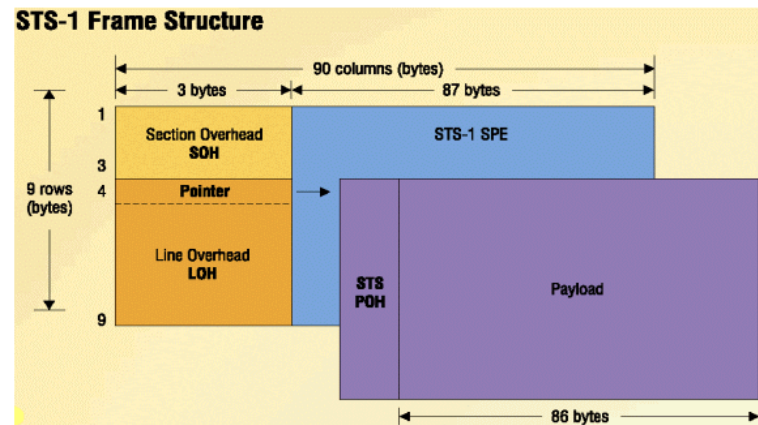

Framing

STS-1 Frame Structure

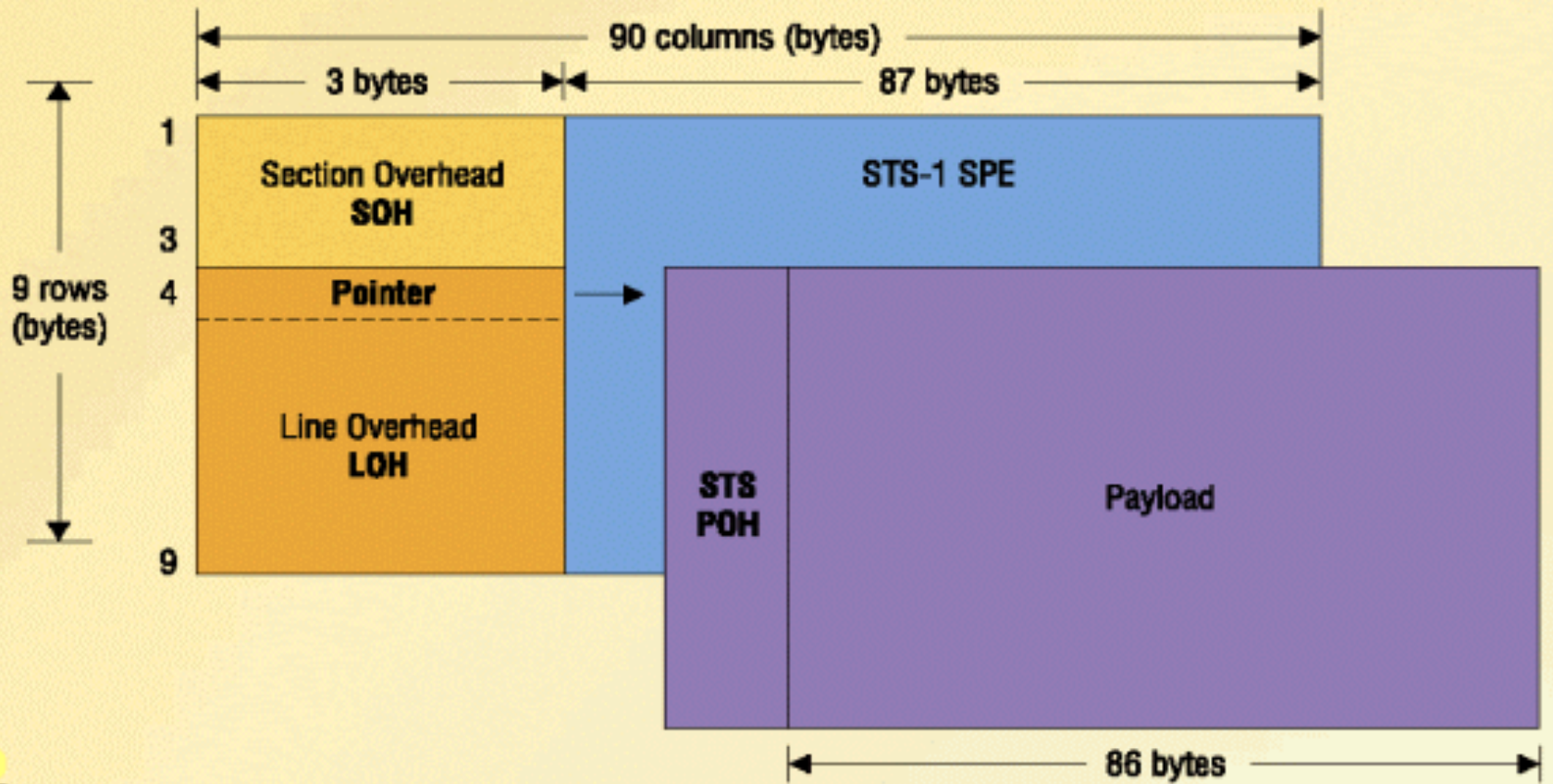

SONET Frame

- Lower-speed non-SONET streams below the STS-1 rate are mapped into virtual tributaries (VTs)
 - Four VT sizes
 - SDH uses Virtual Container (VC) to accommodate for lower speed signals
- SONET allows multiplexing lower-speed asynchronous streams into Virtual Tributary

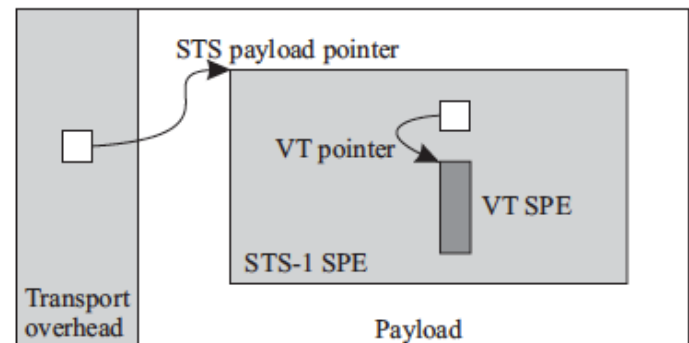
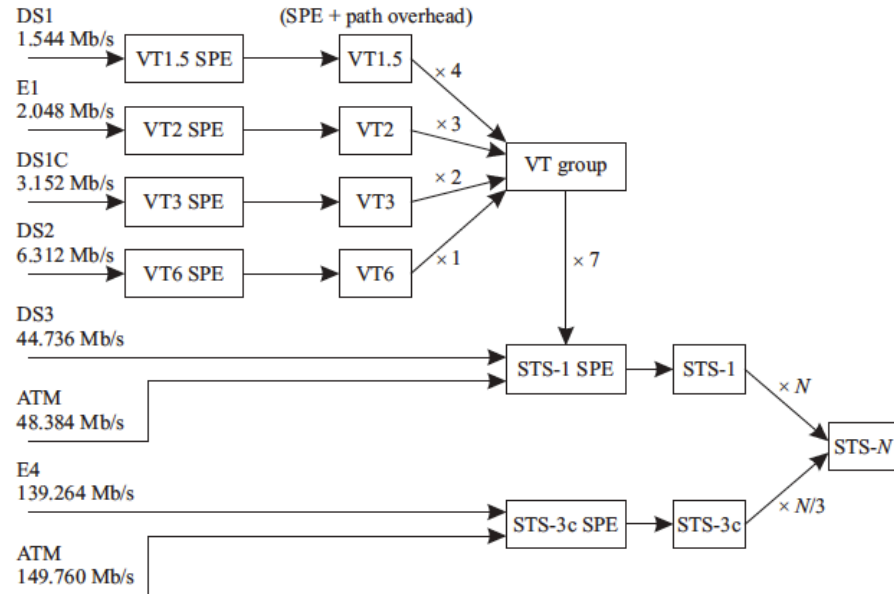

SONET Concatenation

- An STS-**N**c signal with a locked payload is also defined in the standards
 - The “c” stands for concatenated
 - **N** is the number of STS-1 payloads
- The concatenated or **locked** payload implies that this signal cannot be demultiplexed into lower-speed streams
- Example: 150 Mb/s client signal can be mapped into an STS-3c signal

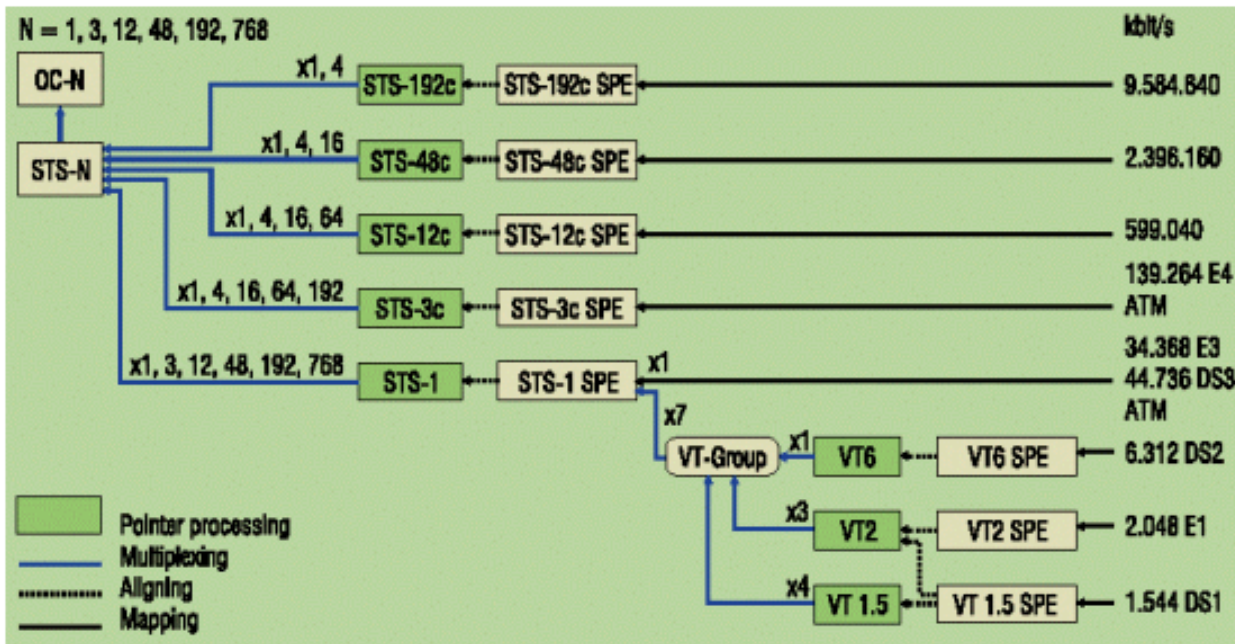

How do we use SONET to carry Gigabit Ethernet?

Virtual Concatenation

- Virtual Concatenation (VCAT) allows noncontiguous payloads to be combined as a single connection
- Such a grouping is referred to as a virtual concatenation group (VCG)
- The VCAT notation for SONET
 - STS-**N** -**M** v
 - **N** is the size of a member & **M** is the number of members in a VCG
- Example: How do we carry GigabitE

STS-3-7V (155 Mbps x 7) about
1.05 (excluding the overhead)
– 5 percent overprovisioning!

SONET Layers

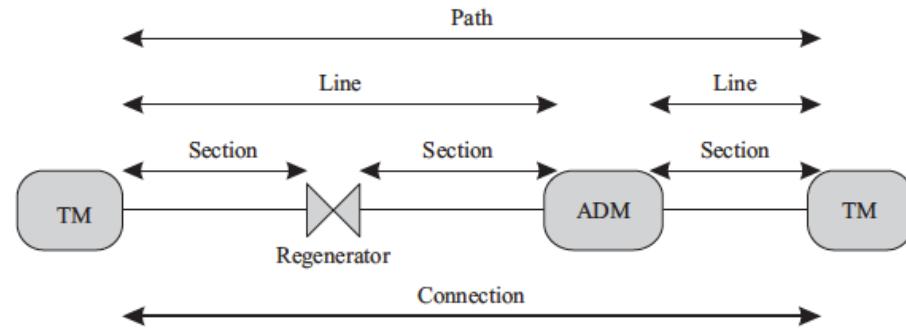

TM: terminal multiplexer (end-to-end) connection
ADM: Add/drop multiplexer

- SONET layer consists of four sublayers
 - path, line, section, and physical layers
- Physical layer interfaces
 - Different rates
 - Electrical / optical
 - Distance (code):
 - Intraoffice (short reach) – I
 - Short haul 15km/1310 or 40km/1550 - S
 - Long haul 40km/1310 or 80km/1550 (400-600 km with Amplifiers) - L
 - Very long haul 60km/1310 or 120km/1550
 - ultra long haul 160km

Different Physical Interfaces for SDH (similar for SONET)

Bit Rate	Code	Wavelength (nm)	Fiber	Loss (dB)	Transmitter	Dispersion (ps/nm)
STM-1	I-1	1310	G.652	0-7	LED/MLM	18/25
	S-1.1	1310	G.652	0-12	MLM	96
	S-1.2	1550	G.652	0-12	MLM/SLM	296/NA
	L-1.1	1310	G.652	10-28	MLM/SLM	246/NA
	L-1.2	1550	G.652	10-28	SLM	NA
	L-1.3	1550	G.653	10-28	MLM/SLM	296/NA

- Fiber type
 - Standard single-mode fiber (G.652)
 - Dispersion-shifted fiber (G.653)
 - Nonzero dispersion-shifted fiber (G.655)
- The transmitter types
 - LEDs or multilongitudinal mode (MLM), single-longitudinal mode (SLM) distances

Physical Layer

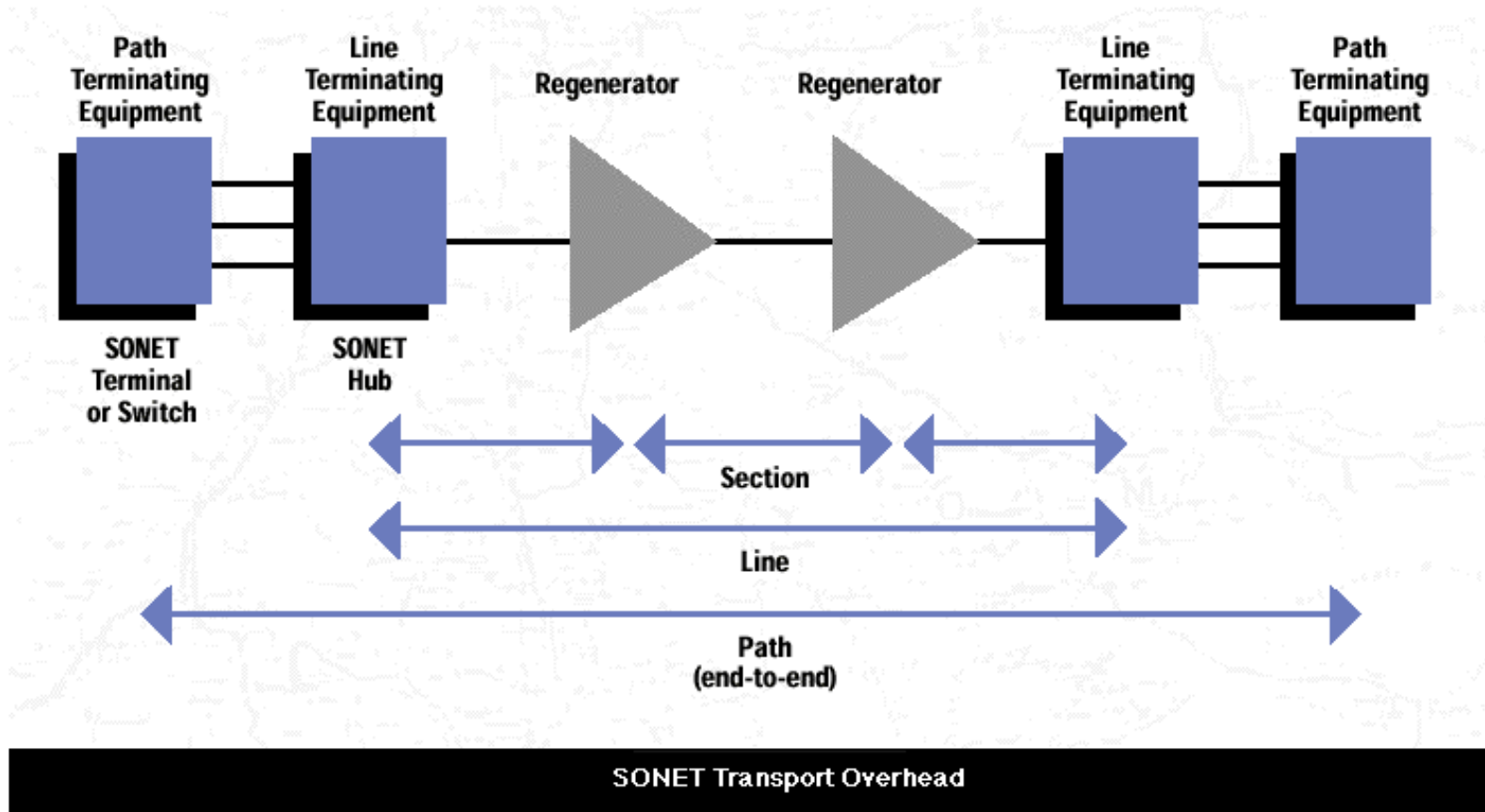

SONET Elements

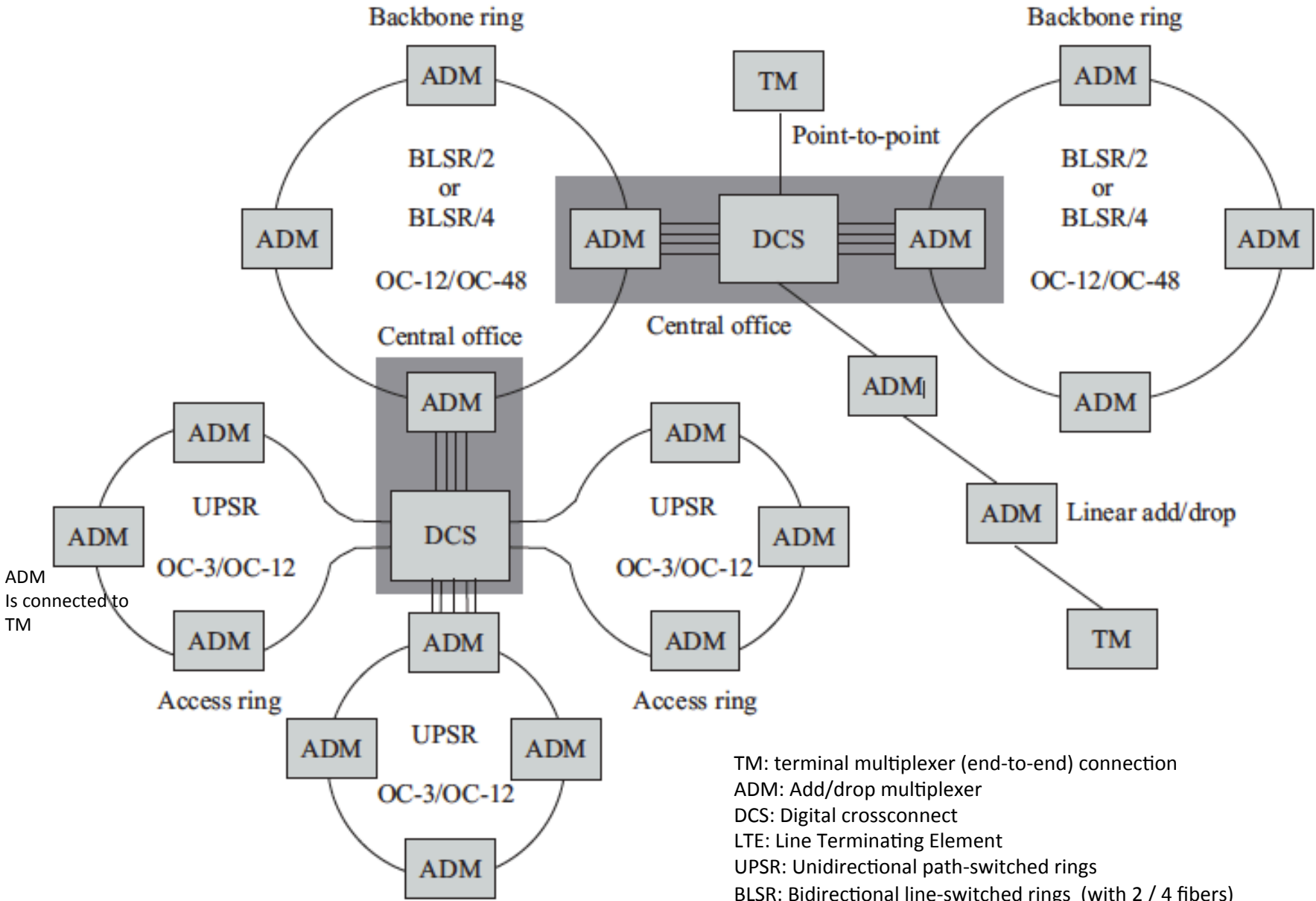

ADM
Is connected to
TM

SONET Elements

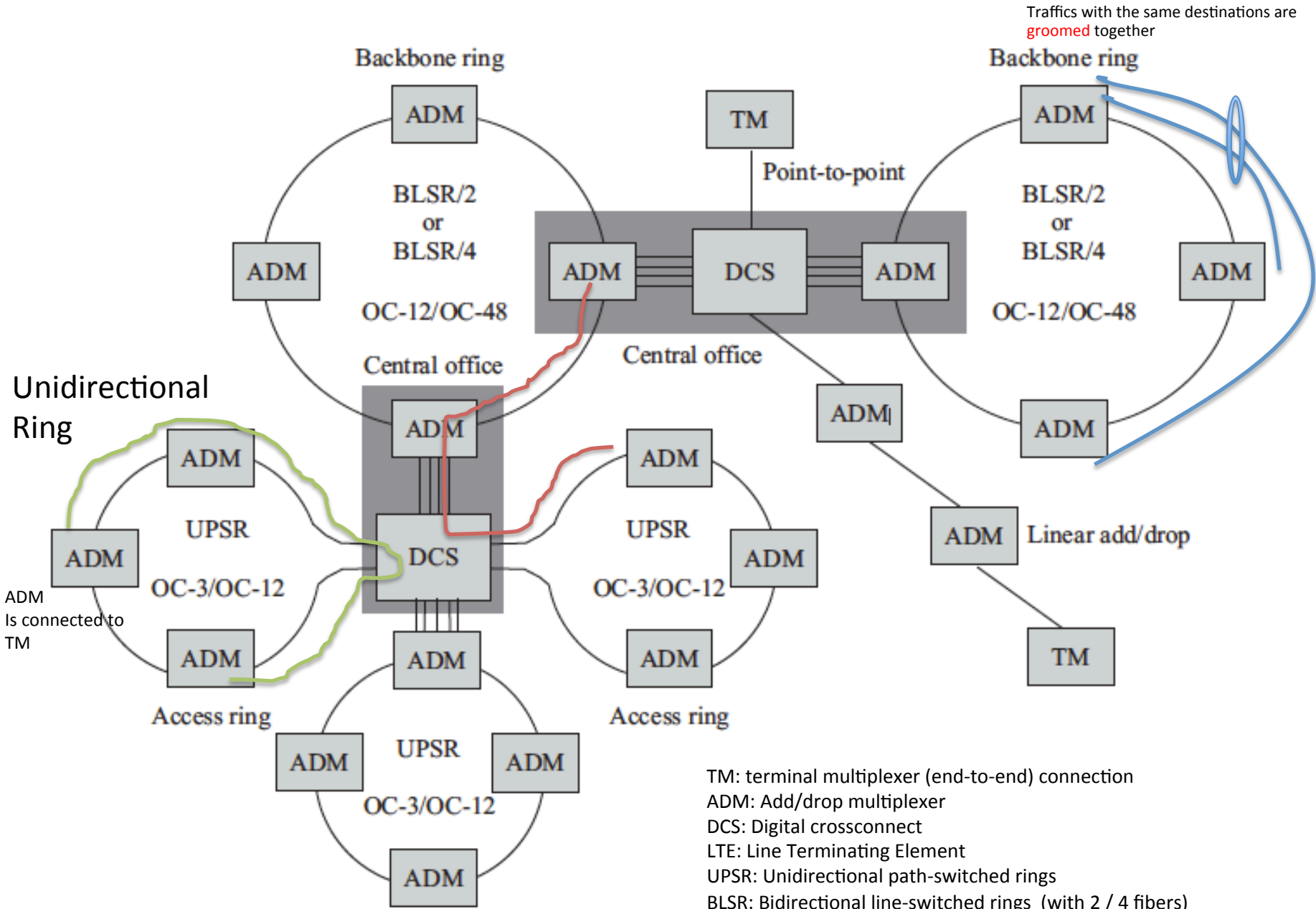

TM: terminal multiplexer (end-to-end) connection
 ADM: Add/drop multiplexer
 DCS: Digital crossconnect
 LTE: Line Terminating Element
 UPSR: Unidirectional path-switched rings
 BLSR: Bidirectional line-switched rings (with 2 / 4 fibers)

IP/SONET over WDM

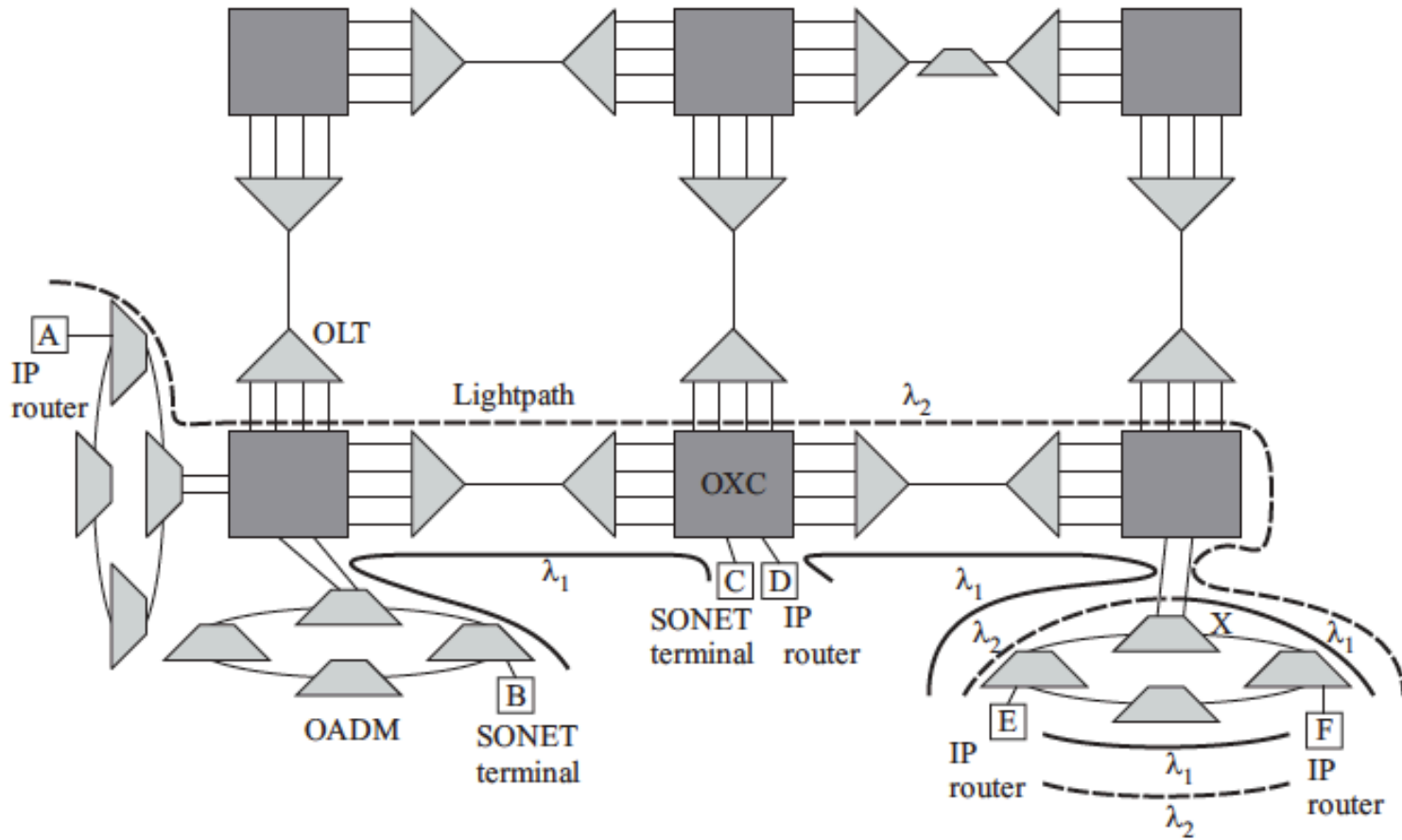

SONET Frame Structure

- STS-1 frame is 125 usec (1/8000 sec/frame)
- There are 810 bytes per frame
 - Transmission row-by-row, left-to-right, MSB first

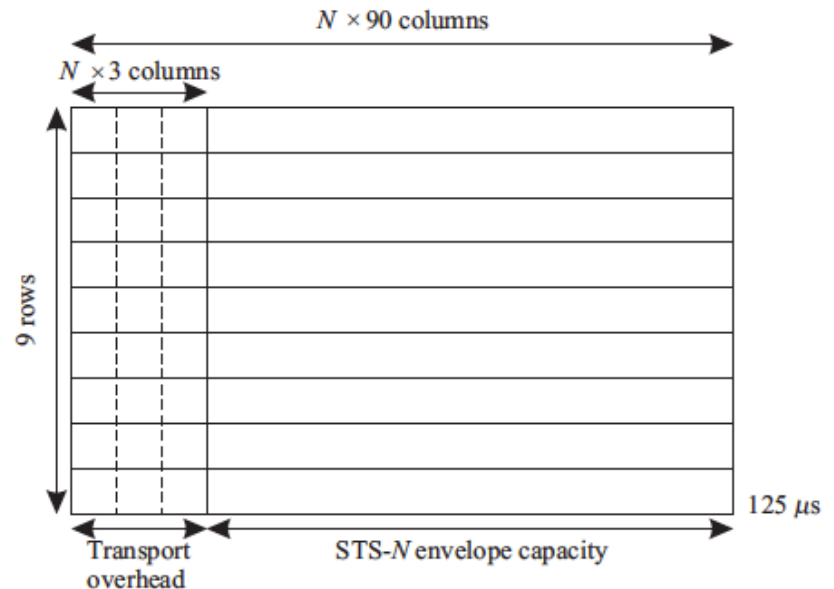
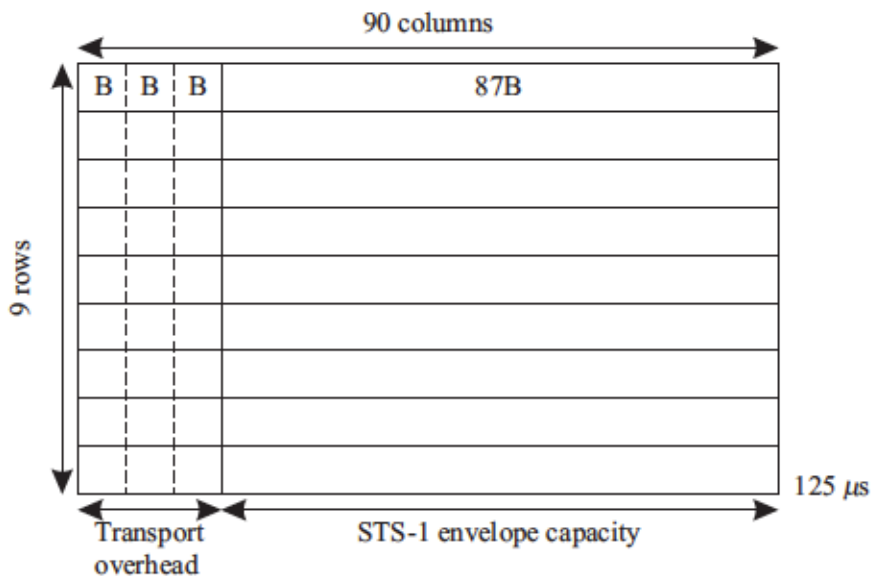

Frame Structure - Overhead

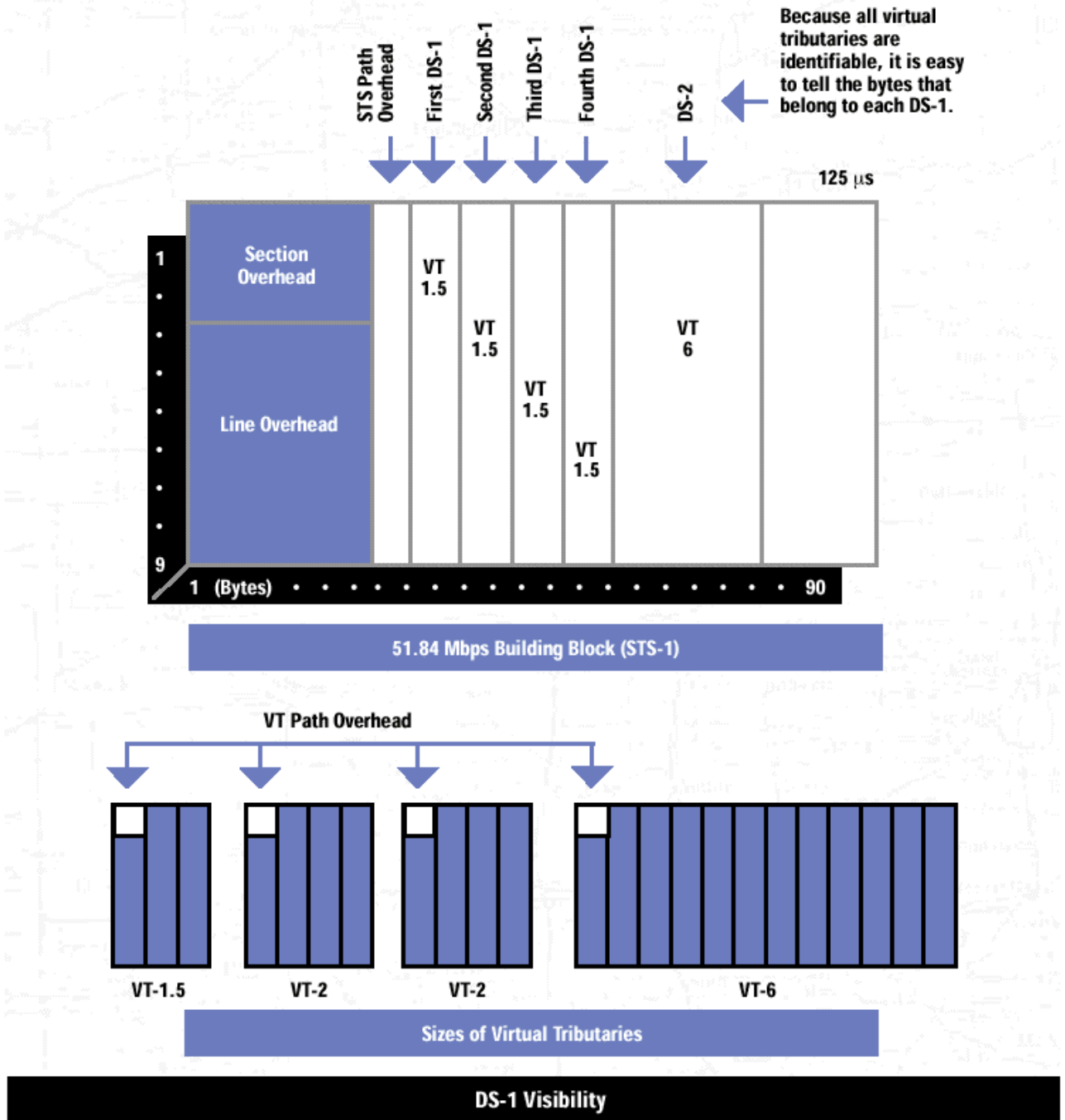

Use of Pointers – Pointer H2 Line Overhead

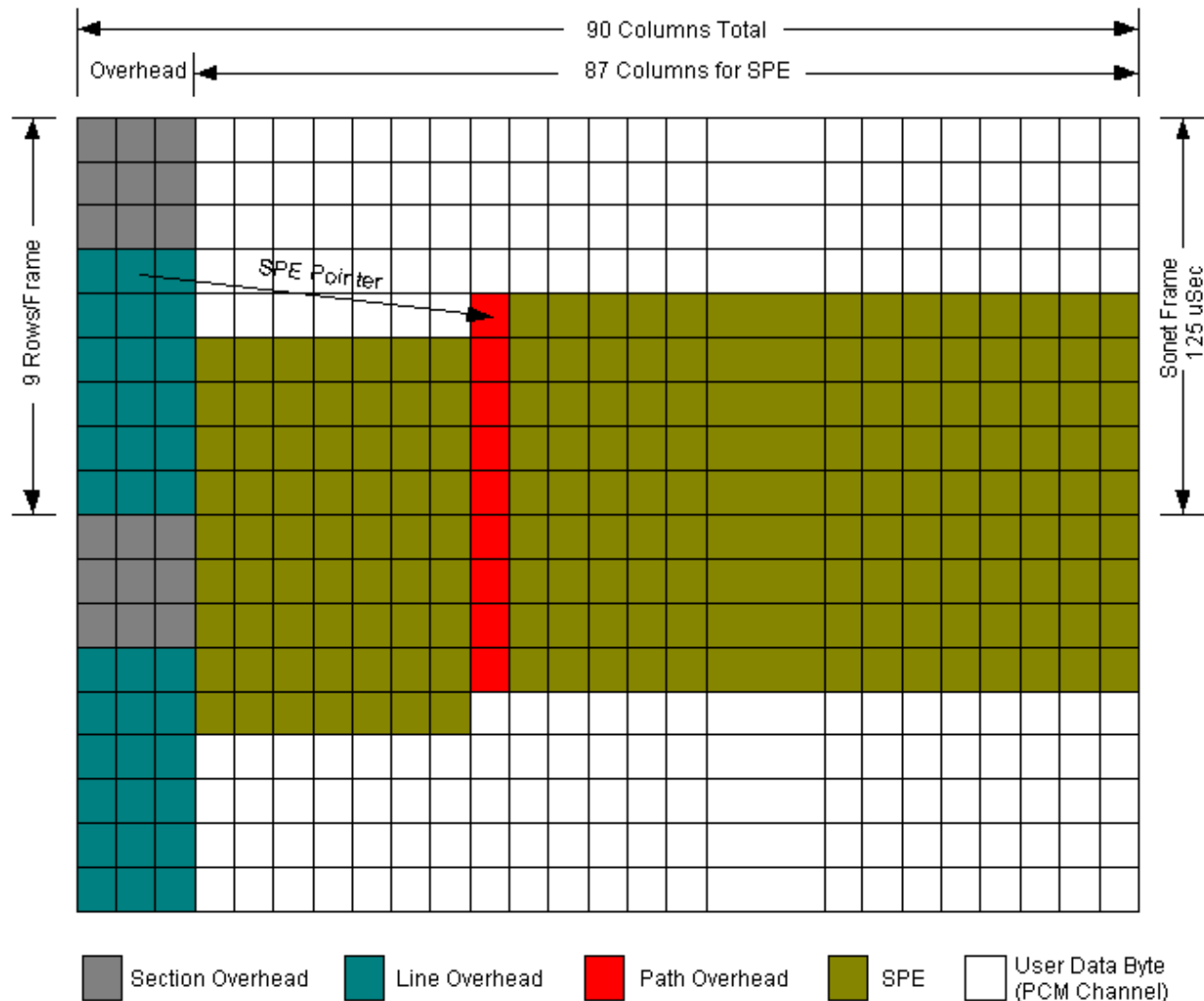

Frame Structure

- A/A2: Network elements use these bytes to determine the start of a new frame
- G1 is Yellow alarm to upstream nodes
- K2 (FERF) alarm for upstream node
- APS indicating automatic switching

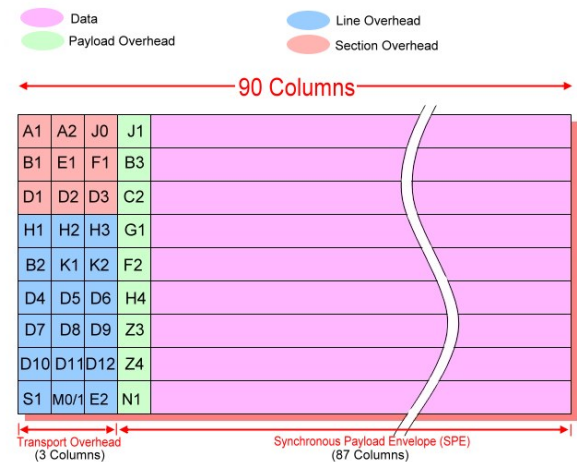
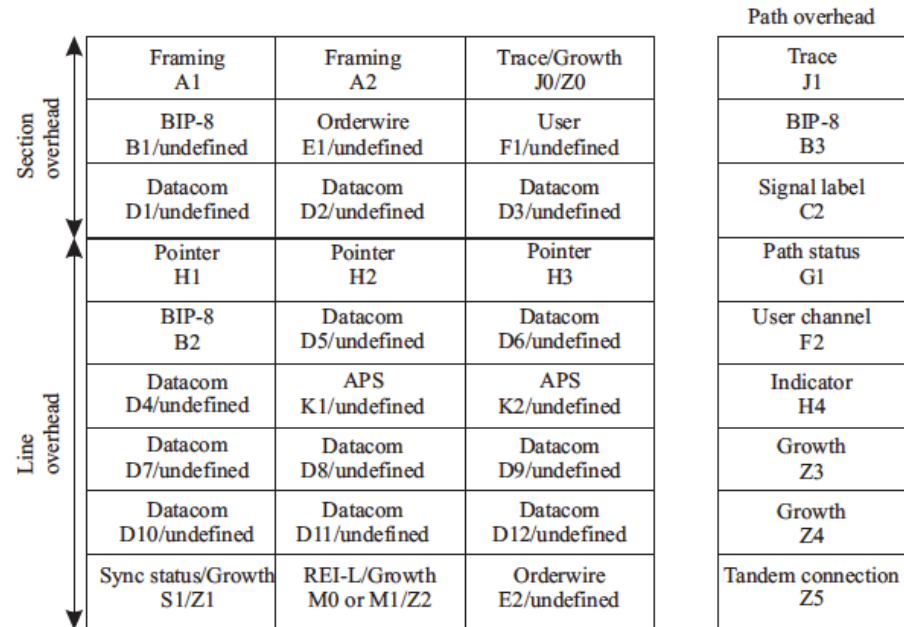

BIP-8 Errors

- Monitoring BIPs
 - Bit interleaved parity
 - Even parity
 - Calculated for the previous frame

X/Y = X applies to the first STS-N; Y is remaining

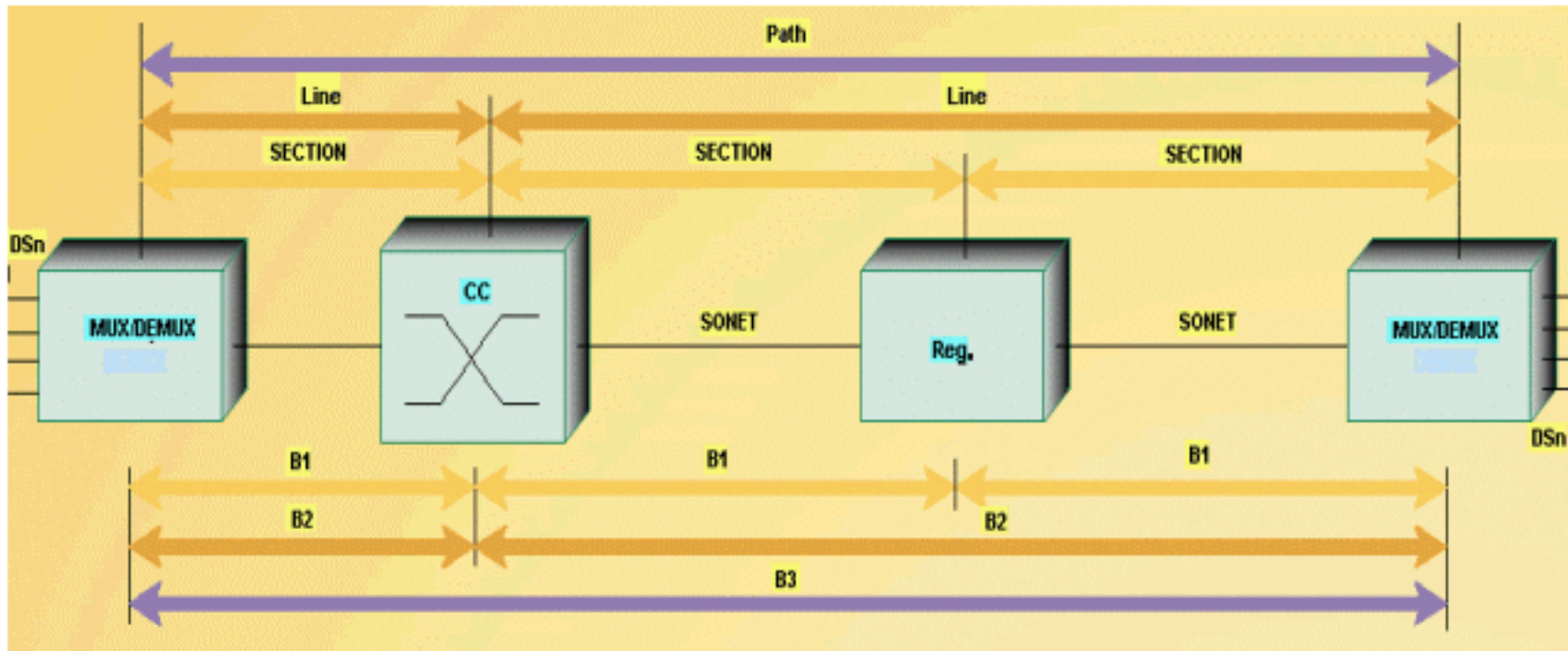
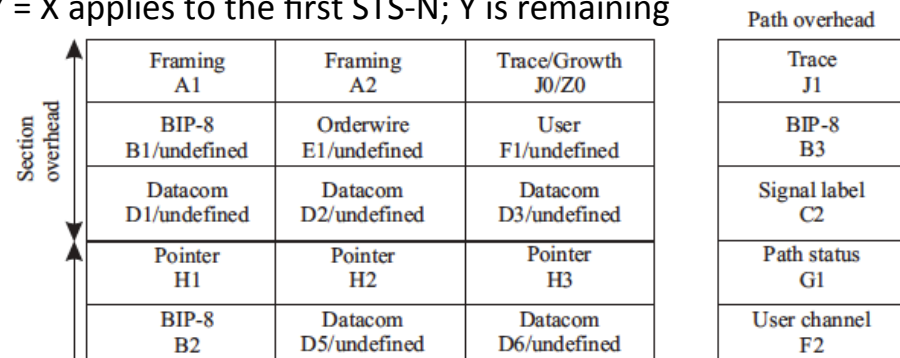

Calculating BIP-8

- Calculated BIP-8 (B1) is based on the previous STS-N frame after scrambling
 - Odd parity means there is an error
- B2 is based on calculating line overhead of the line overhead – checked by the line terminating equipment

Client Layers of Optical Fiber

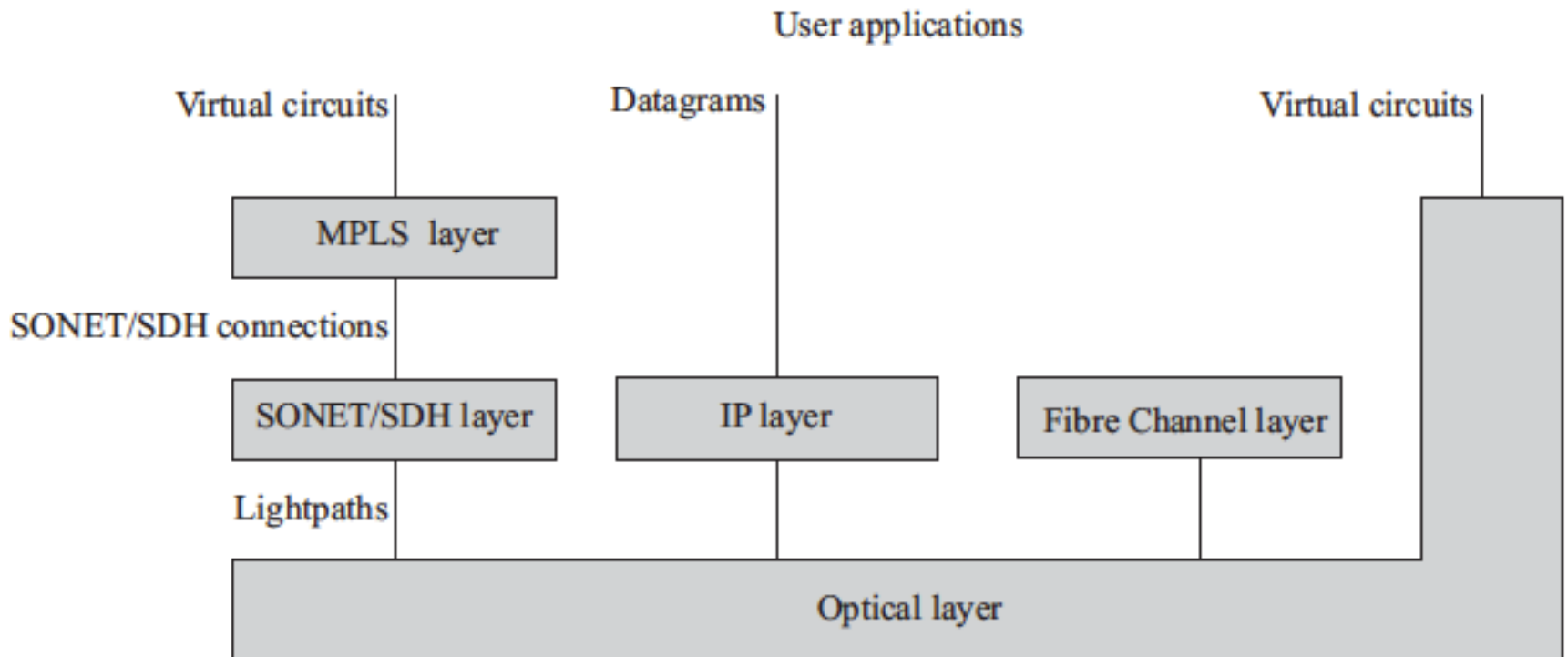

SONET Protection

- Chapter 9 - up to 9.3

SONET Protection

- Availability: A common requirement that the connection will be available 99.999%
- Thus network has to be survivable
 - continue providing service in the presence of failures
- Protection switching is the key technique used to ensure survivability
 - The term restoration to schemes where traffic is restored
- There are many failures
 - Human errors / disasters / Attacks / etc.
 - Component failures
 - Link failures:
 - There are estimates that long-haul networks annually suffer 3 fiber cuts for every 1000 miles of fiber
 - For a large network of 30,000 miles of fiber cable, that would be 90 cuts per year

Protection Key Parameters

- Detect failures
- Protect against failures (single failures)
- Restoration time (60 msec – including detection and restoration)
- Topology (Ring / Mesh)
- Signaling

Basic Protection Concepts

- Failures must be protected!
- Failure types:
 - Single / multiple / double (a series of shared links can fail)
- Failure example:
 - Node / Link (Fiber) / Components
- Protection type
 - Shared
 - Dedicated
- Scheme
 - Revertive – when shared protection is used
 - Non-revertive – when 1+1 is used

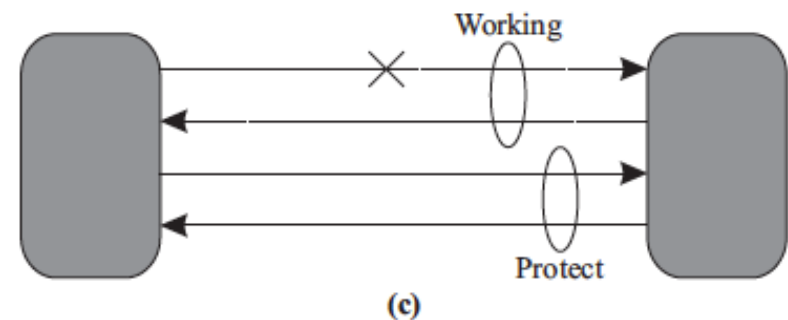
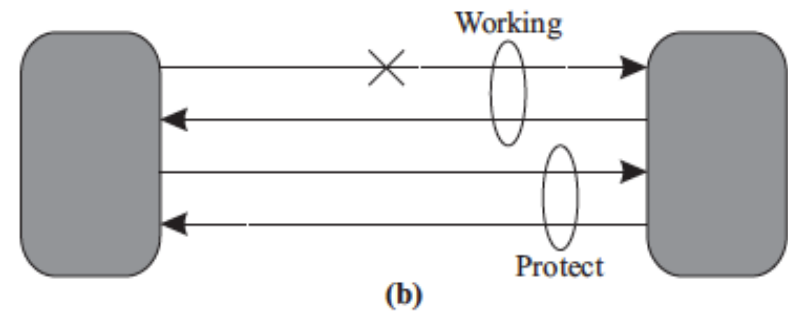
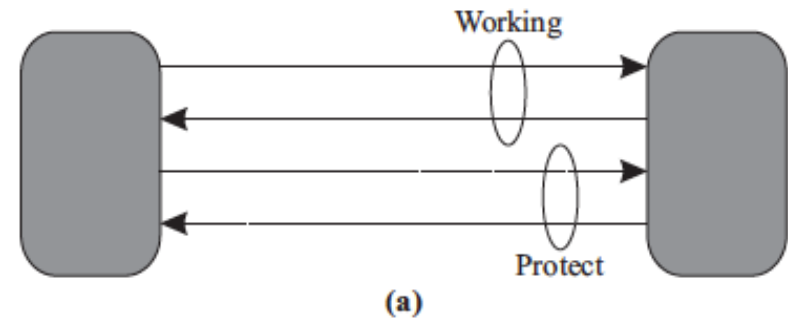

Protection Switching

- Automatic Protection Switching (ASP)
- Unidirectional
 - ASP Required
 - Signaling is required
- Bidirectional
 - No ASP is required

Case b: Only affected direction is switched: - Unidirectional

Protection switching (**RED is working**)

Case c: Bidirectional protection

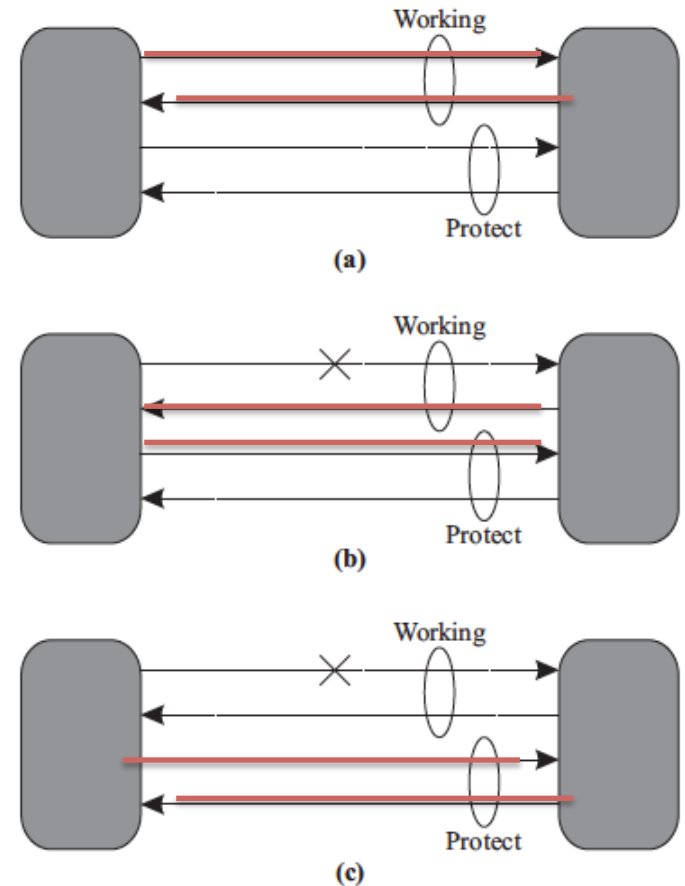

Traffic Routing Due to Protection Switching – how the traffic is being rerouted due to link failure

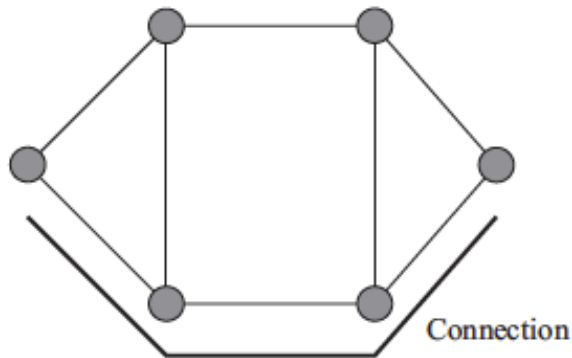

(a)

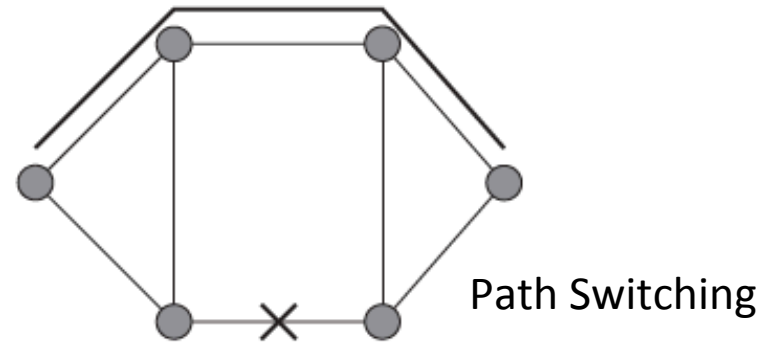

(b)

Path Switching

Span Switching

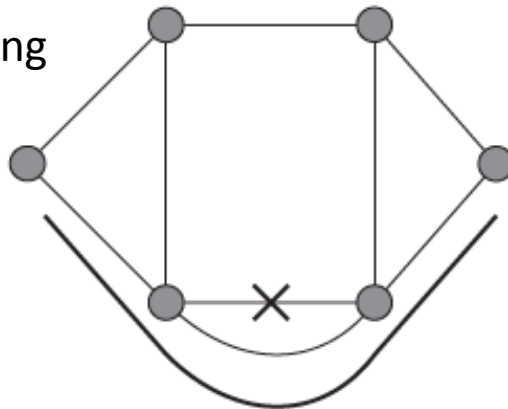

(c)

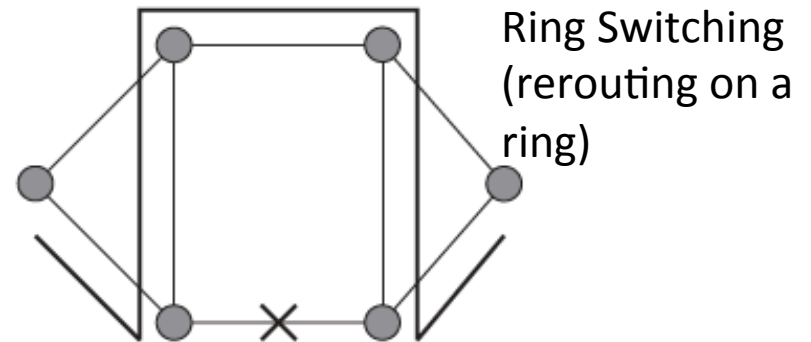

(d)

Ring Switching
(rerouting on a ring)

Protection Techniques

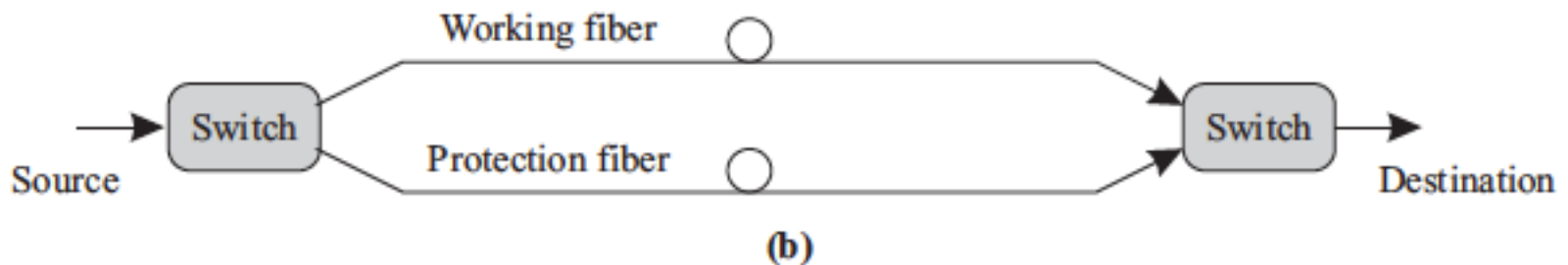
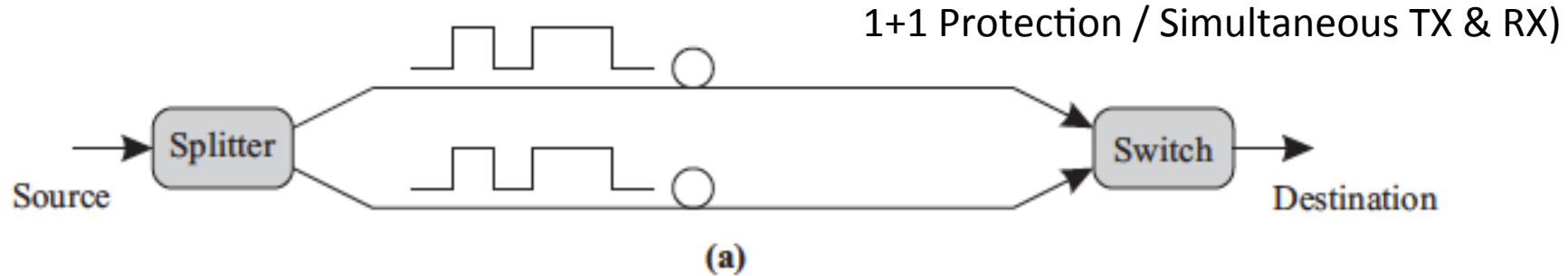

1:1 Protection / Signaling is required

To activate the protection / traffic must be switched /

The protection links can carry EXTRA traffic – low priority

Protection Schemes

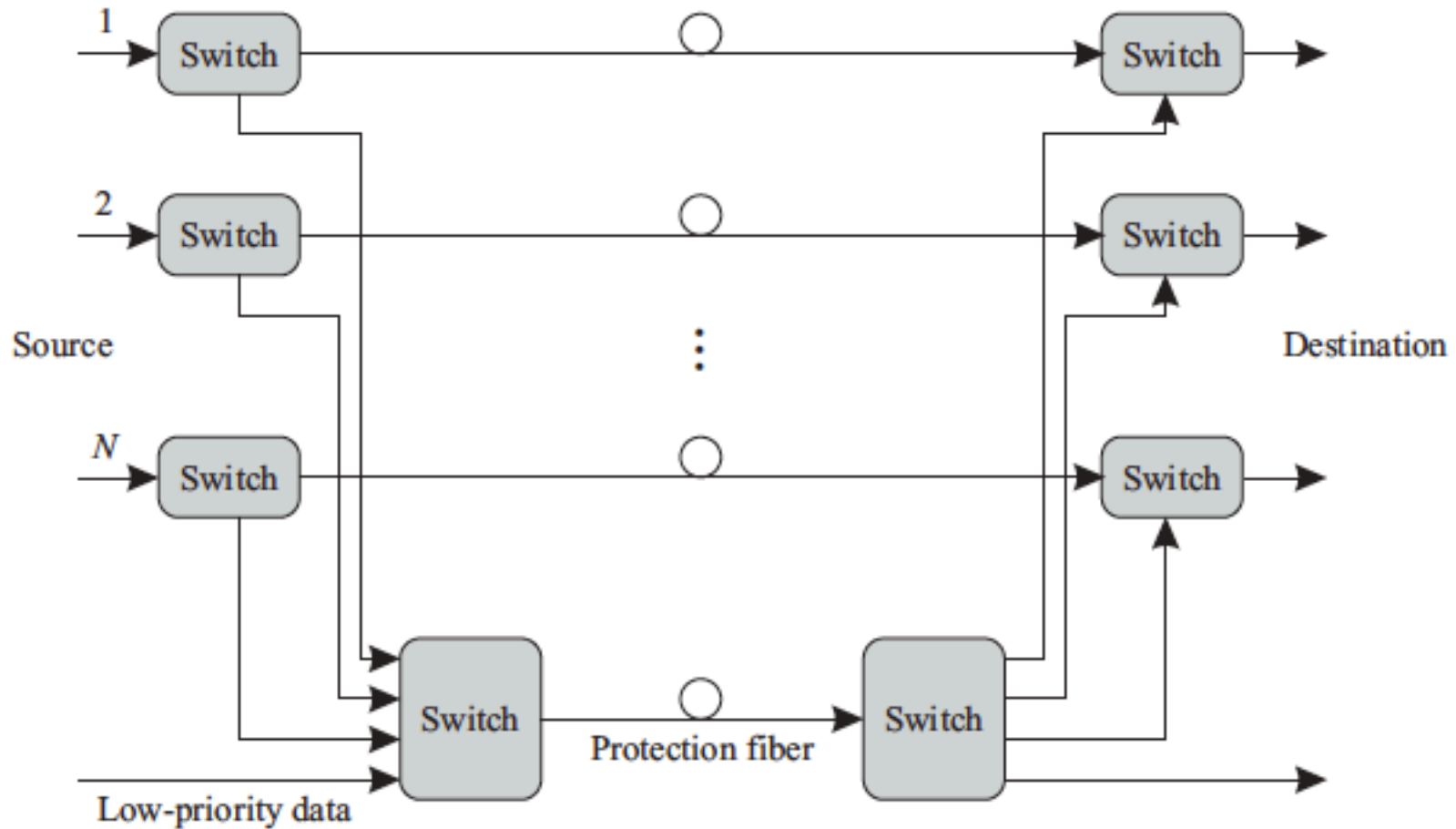

1:N Protection / Shared Protection / Signaling is required /
Typically, must be revertive!

SONET Rings and Self-Healing Rings

- Unidirectional path-switched ring (UPSR)

- 1+1 Protection
- Two Fibers only
- Unidirectional
- Simultaneous traffic (clockwise and counter CW)
- Path Layer Protection
- Simple / requires no signaling
- No node limitation / no length limitation

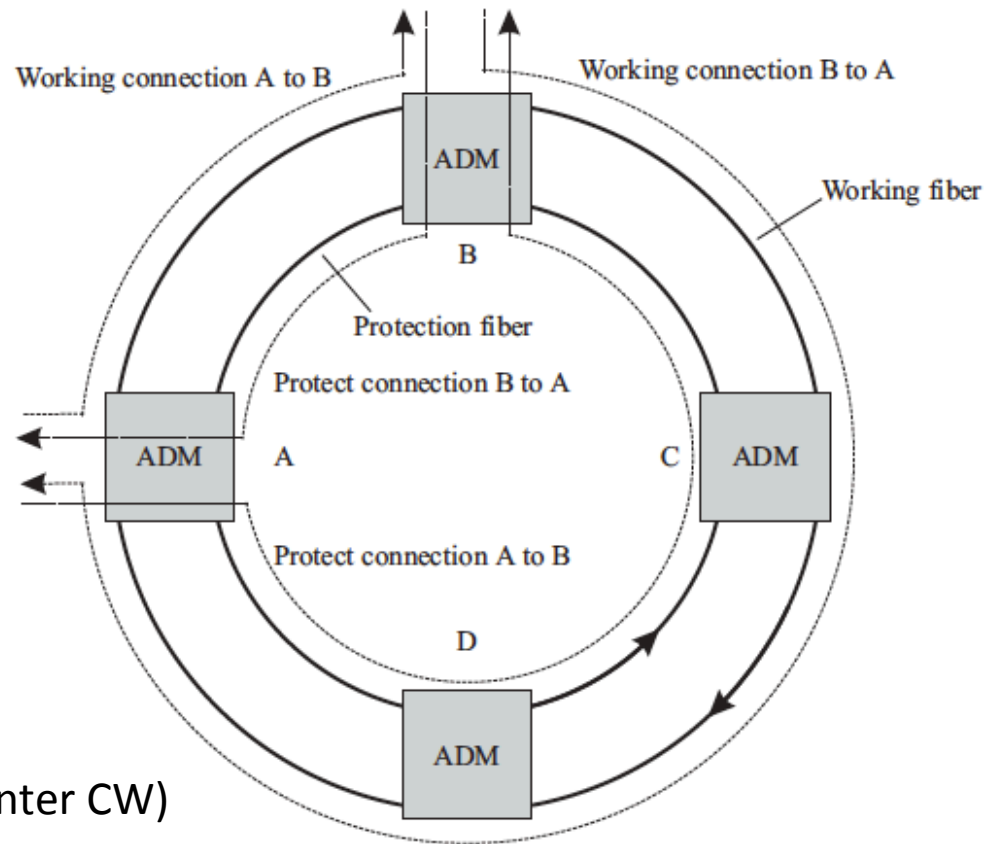

Note: It is important that the traffics are moving in DIFFERENT directions to protect against any node failure

Four Fiber Bidirectional Lines Switched Ring (BLSR/4)

- Mainly, line protection
- Traffic is on both directions
 - CW and CCW
- Max of 16 nodes are supported
- Max length is 1600 km
- Supports span switching or ring switching (next slide)

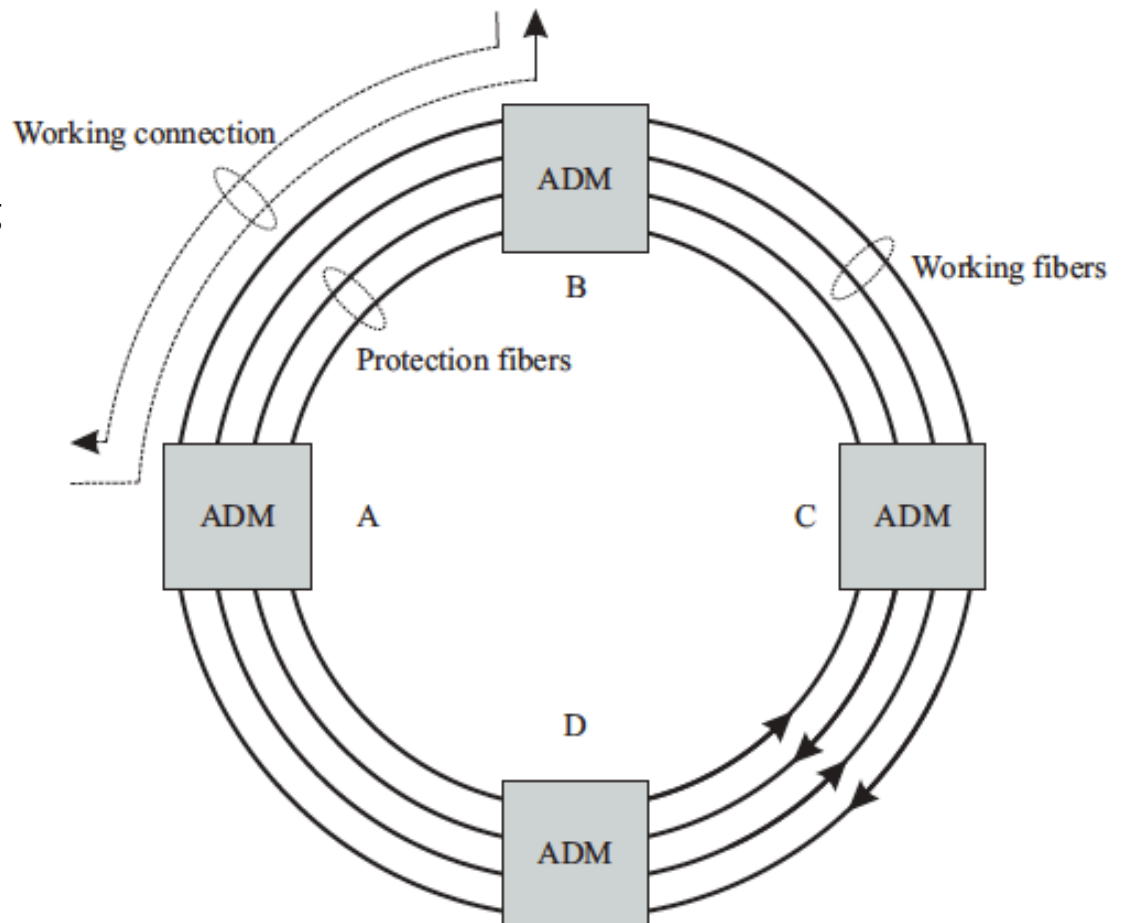

SPAN / RING Switching in BLSR/4

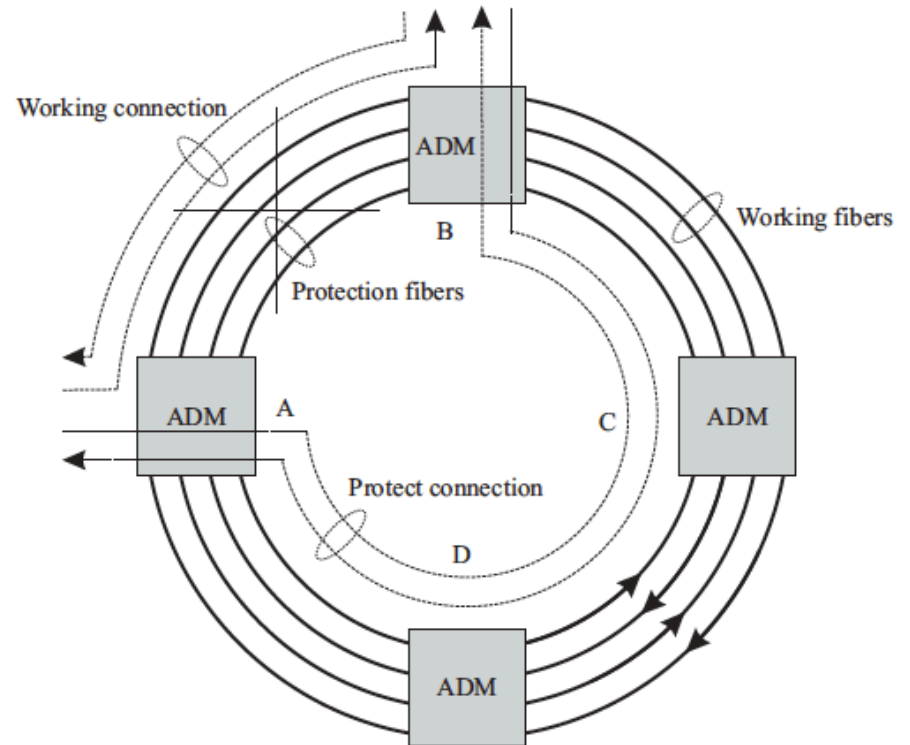
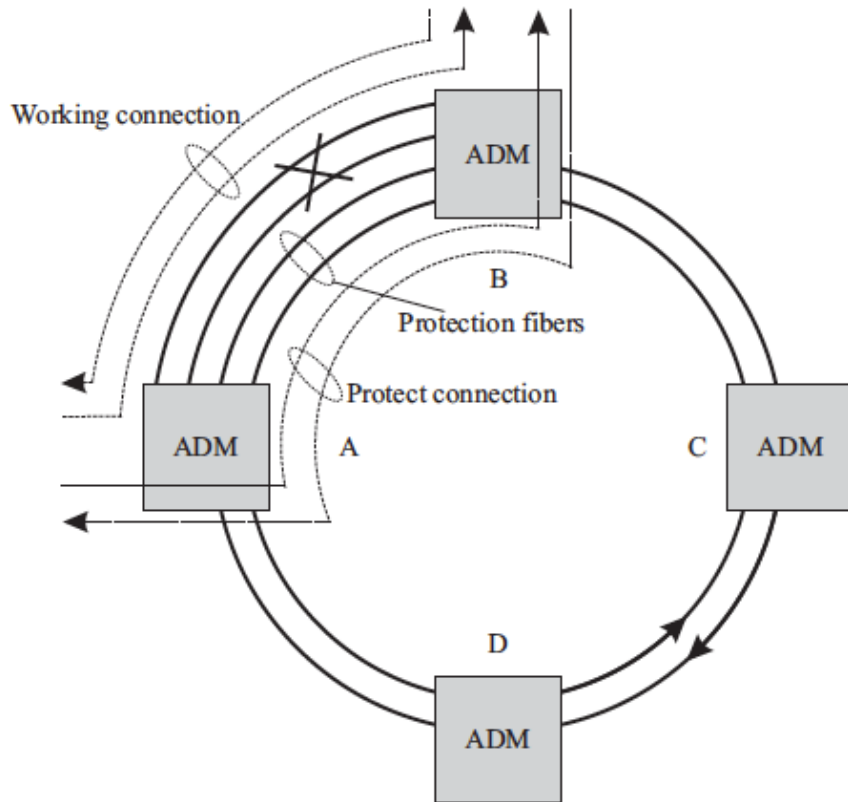

Two-fiber bidirectional line-switched Ring (BLSR/2)

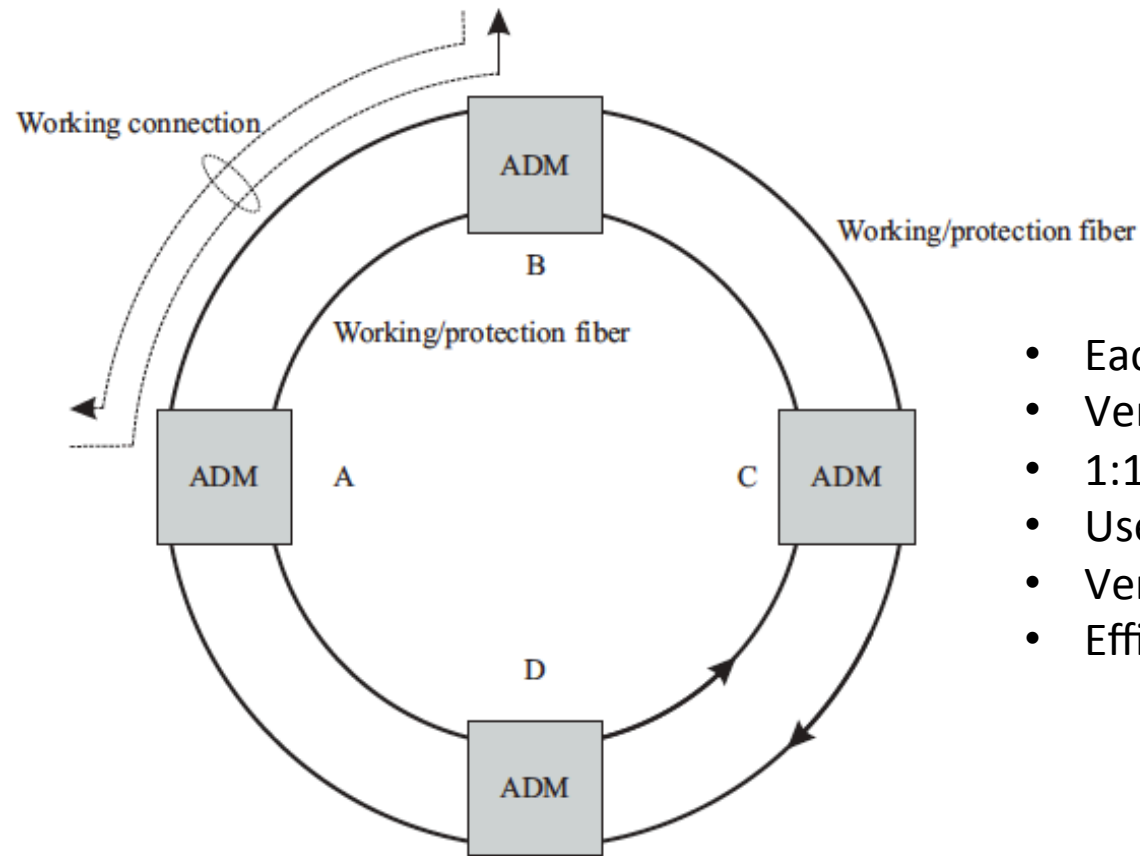

- Each link has half BW
- Very complex – uses APS (K1/K2 bytes)
- 1:1 Switching
- Used for long haul
- Very common
- Efficient use of special capacity

Example: BLSR/2 is much more efficient than UPSR (2 fiber)

Node Failure

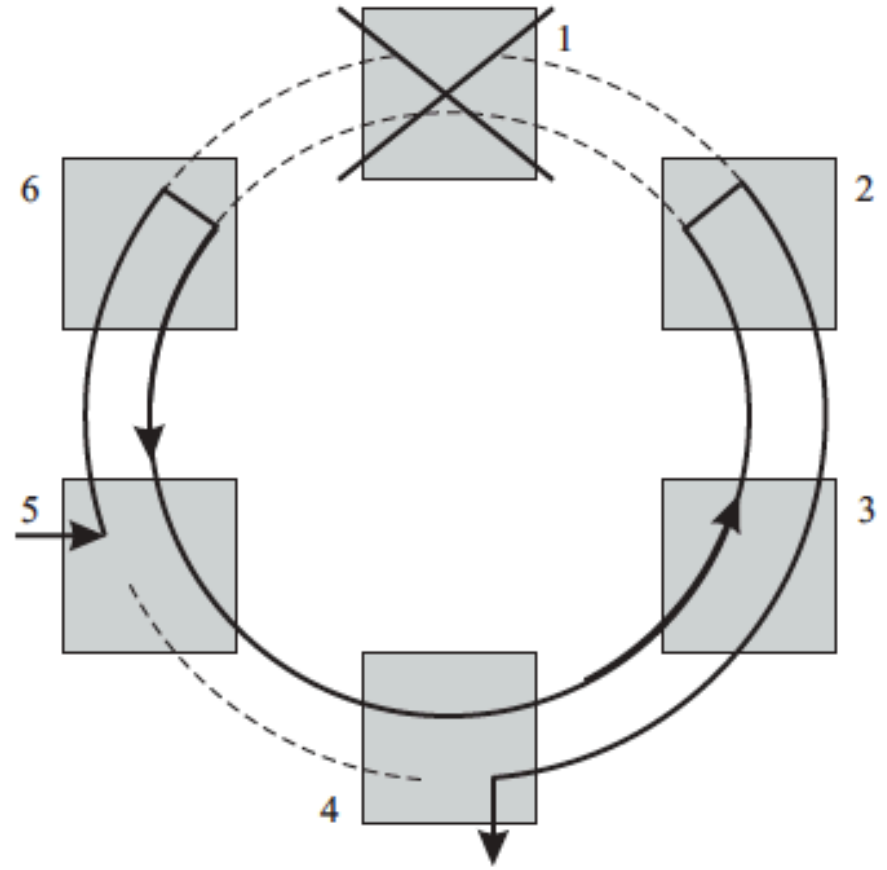
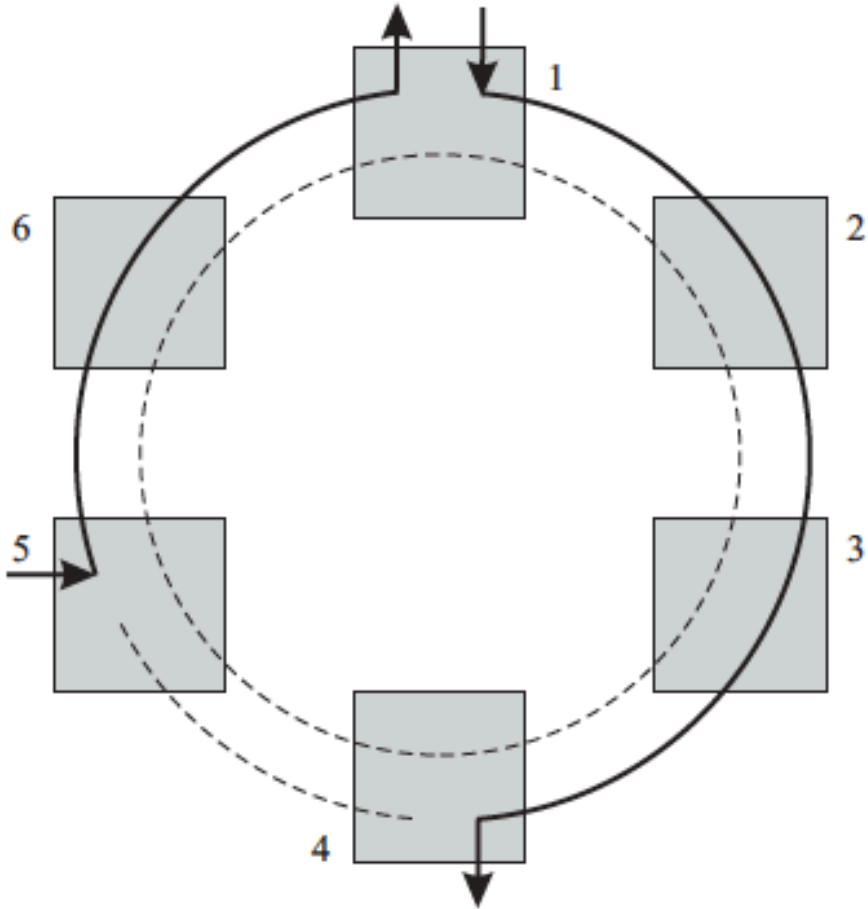

Lab

Framing Review

STS-1 Frame Structure

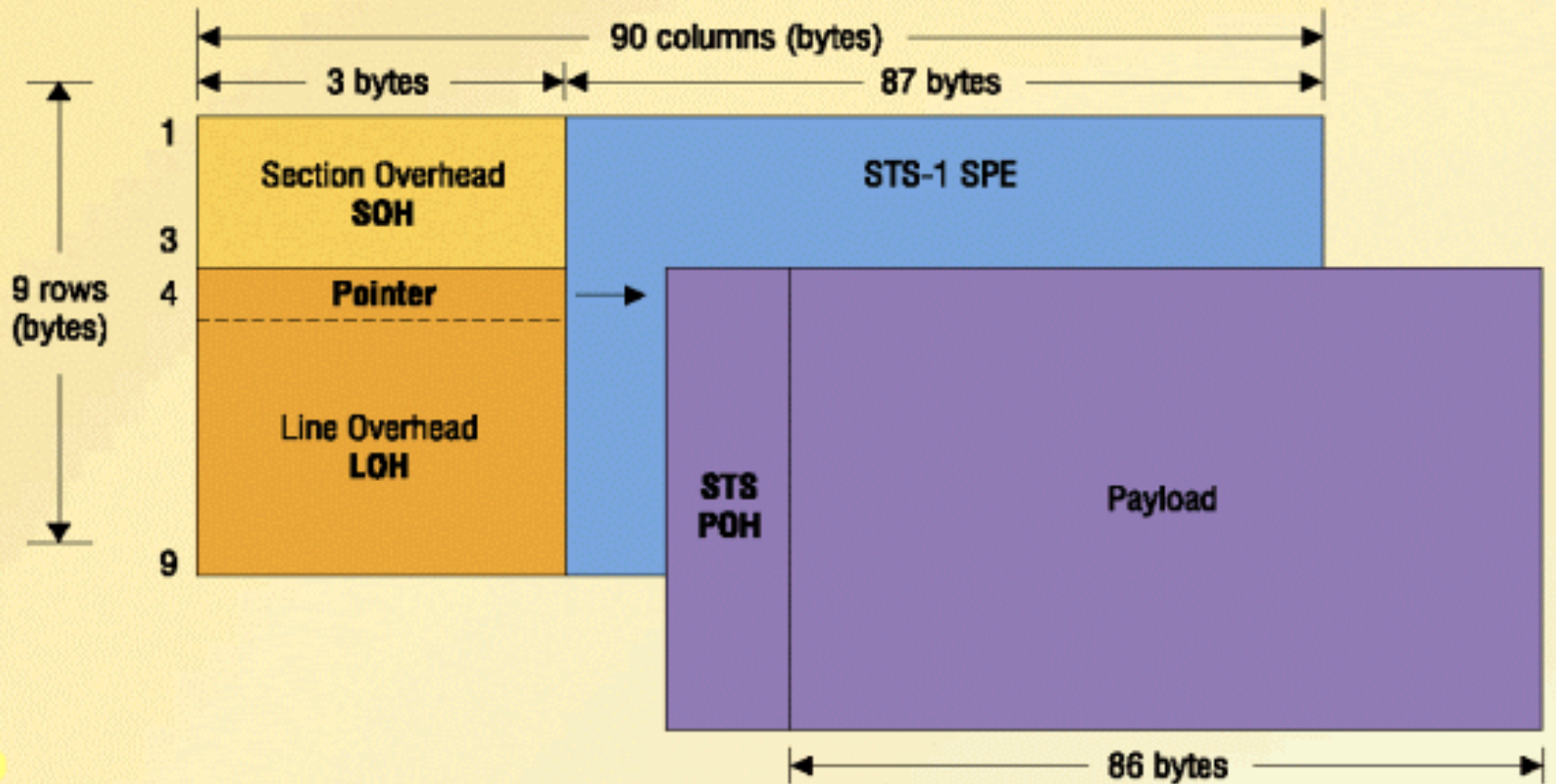

LAB

SOH Section Overhead

A1, A2: Indicates the beginning of each STS-1 within a STS-n frame. The pattern is Hex F628.

J0: Section trace. It is defined only for STS-1 number 1 of an STS-N signal. Used to transmit a one byte fixed length string or a 16 byte message so that a receiving terminal in a section can verify its continued connection to the intended transmitter.

Z0: Section growth. It is defined in each STS-1 for future growth except for STS-1 number 1 (which is defined as J0).

B1: Section error monitoring. The BIP-8 is calculated over all bits of the previous STS-N frame after scrambling and is placed in the B1 byte of STS-1 number 1 before scrambling. Defined only for STS-1 number 1 of an STS-N signal.

E1: Allocated to be used as local orderwire channels for voice communication between section terminating equipments, hubs and remote terminal locations.

F1: Reserved for user purposes (e.g. temporary data/voice channel connections for special maintenance purposes).

D1 - D3: Data communication channels (DCC). A 192 kbit/s message based channel for alarms, maintenance, control, monitoring, administration and other communication needs.

Framing Bytes

LOH Line Overhead

H1, H2: Pointer bytes. Allocated to a pointer that indicates the offset in bytes between pointer and the first byte of the STS SPE. It is used to align the STS-1 transport overheads in an STS-N signal as well as perform frequency justification.

H3: Pointer action byte. It is used for frequency justification. Depending on the pointer value, this byte is used to adjust the fill input buffers. It only carries valid information in the event of negative justification, otherwise it's not defined.

B2: Line error monitoring. The BIP-8 is used to determine if a transmission error has occurred over a line. It is calculated over all bits of the previous STS-1 frame before scrambling and is placed in the B2 byte of the current frame before scrambling.

K1, K2: Allocated for APS (Automatic Protection Switching) signaling for the protection of the multiplex section.

Connection Setup

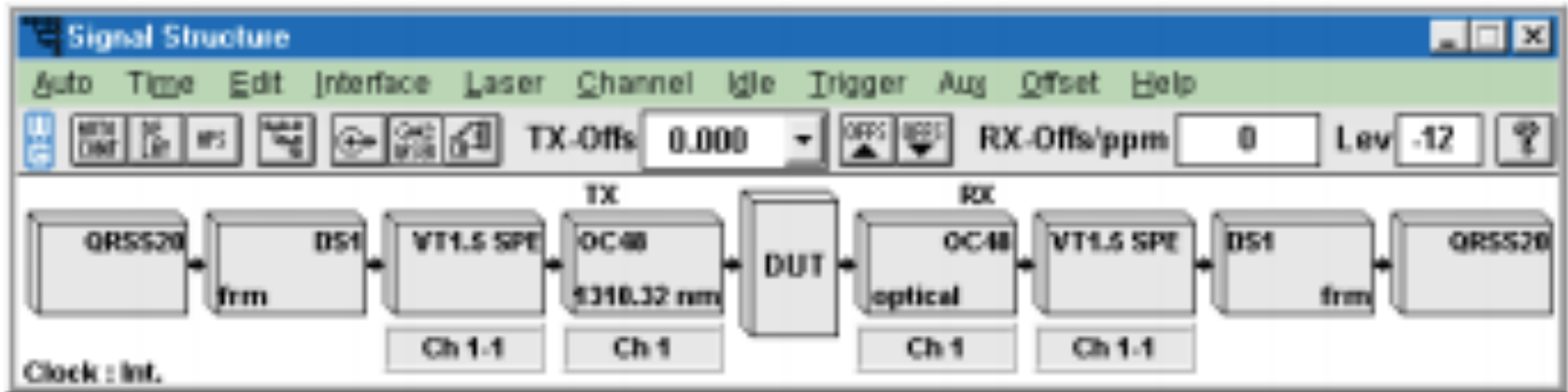

Pseudo-random bit sequences – max 14 consecutive zeros

References

- http://www.cisco.com/en/US/tech/tk482/tk607/technologies_tech_note09186a0080094313.shtml
- http://www.opticus.co.uk/pdf/WhitePaper-Understanding_Error_Checking_Using_Parity_Bytes.pdf